

Section 5 – Three-Phase Metering

| | | |
|-------------|--|-----------|
| 5-1 | General Three-Phase Requirements | 2 |
| 5-2 | 200A – 320A Three-Phase Overhead..... | 3 |
| 5-3 | 400A – 3000A Three-Phase Overhead – CT Metered..... | 4 |
| 5-4 | 200A – 320A Three-Phase Underground..... | 5 |
| 5-5 | 400A – 3000A Underground - CT Metered in Pad mounted Transformer | 6 |
| 5-6 | 400A – 3000A Underground - CT Metered in CT Cabinet..... | 7 |
| 5-7 | Space Required to Terminate in Service Entrance Panels & Switchgear..... | 10 |
| 5-8 | Termination Enclosures..... | 12 |
| 5-9 | Large CT Installation, Bus Bars – 2500 - 3000 Amp – Metering in Switchgear | 14 |
| 5-10 | Large CT Installation, Doughnuts – 2500 - 3000 Amp – Metering in Switchgear | 15 |
| 5-11 | Standard Pad for 75 - 2500 KVA Pad mount Transformers | 16 |
| 5-12 | Large Concrete Pad for 3750 - 5000 KVA Pad mount Transformers..... | 18 |
| 5-13 | Primary Metering..... | 20 |

5-1 General Three-Phase Requirements

Three-Phase 120/208 Ampacities – Grounded Wye (4-wire)

- 200 Amp
- 320 Amp
- 400 Amp - 2000 Amp (CT metering required)

Three-Phase 277/480 Ampacities – Grounded Wye (4-wire)

- 200 Amp
- 400 Amp - 3000 Amp (CT metering required)

Historic Configurations – No longer offered as a new service

- Three-Phase Ungrounded Wye (3-wire)
 - If the customer service is upgraded, the Company will pull a 4th wire.
- Three-Phase Open Delta (3-wire)
 - If the customer service is upgraded, the Company will upgrade the transformer bank to wye configuration and pull a 4th wire.
- Three-Phase 120/240 Grounded Delta (4-wire)

General Three-Phase Meter Socket Requirements

1. Ringless style, 200 Amp minimum rated, clamp type jaws, 600 Volt rated, sealable, and provided with protective shield covering the jaws.
2. The meter sockets shall have a manual bypass that is designed so the cover cannot be installed with the bypass closed.
3. The phase designations from the Company do not indicate clockwise or counterclockwise rotation.
4. The meter socket (if required for non-CT metering) shall be installed 4-6 ft above ground and be readily accessible to be read, tested, and inspected.

VIEW OF METER SOCKETS

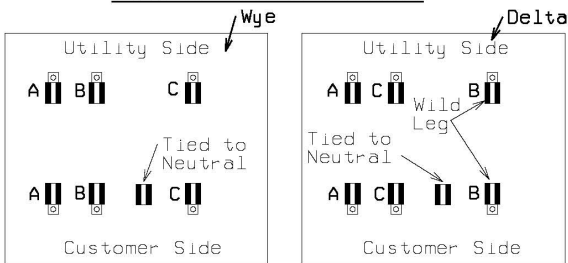

7 Jaw Meter Socket

Used for:
 120/208 4-wire 3 Ø wye
 277/480 4-wire 3 Ø wye
 120/240 4-wire 3 Ø delta

For 120/240 4-wire 3 Ø the far right side shall be connected to the wild leg. This conductor shall be identified with orange tape or marked by other approved means.

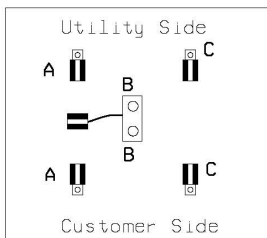

5 Jaw Meter Socket
 Used for 240 Volt 3-wire 3 Ø Delta
 The center conductor is the grounded conductor.

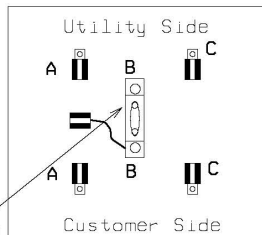

5 Jaw Meter Socket
 Used for 480 Volt 3-wire 3 Ø Delta
 The insulated slide bar is used to disconnect the third phase, if necessary.

Note: 5 Jaw meter sockets are only permitted for maintenance of existing services. New installation of 3 wire 3 phase Delta are prohibited.

5-2 200A – 320A Three-Phase Overhead

Specifications:

- Ringless Type Meter Socket
- For 320A socket, 400A max
- Rated 600V AC
- 3 Phase, 4-Wire
- UL Listed
- 7 Jaw Meter Socket
- Bypass Lever
- Sealable
- No cover over meter

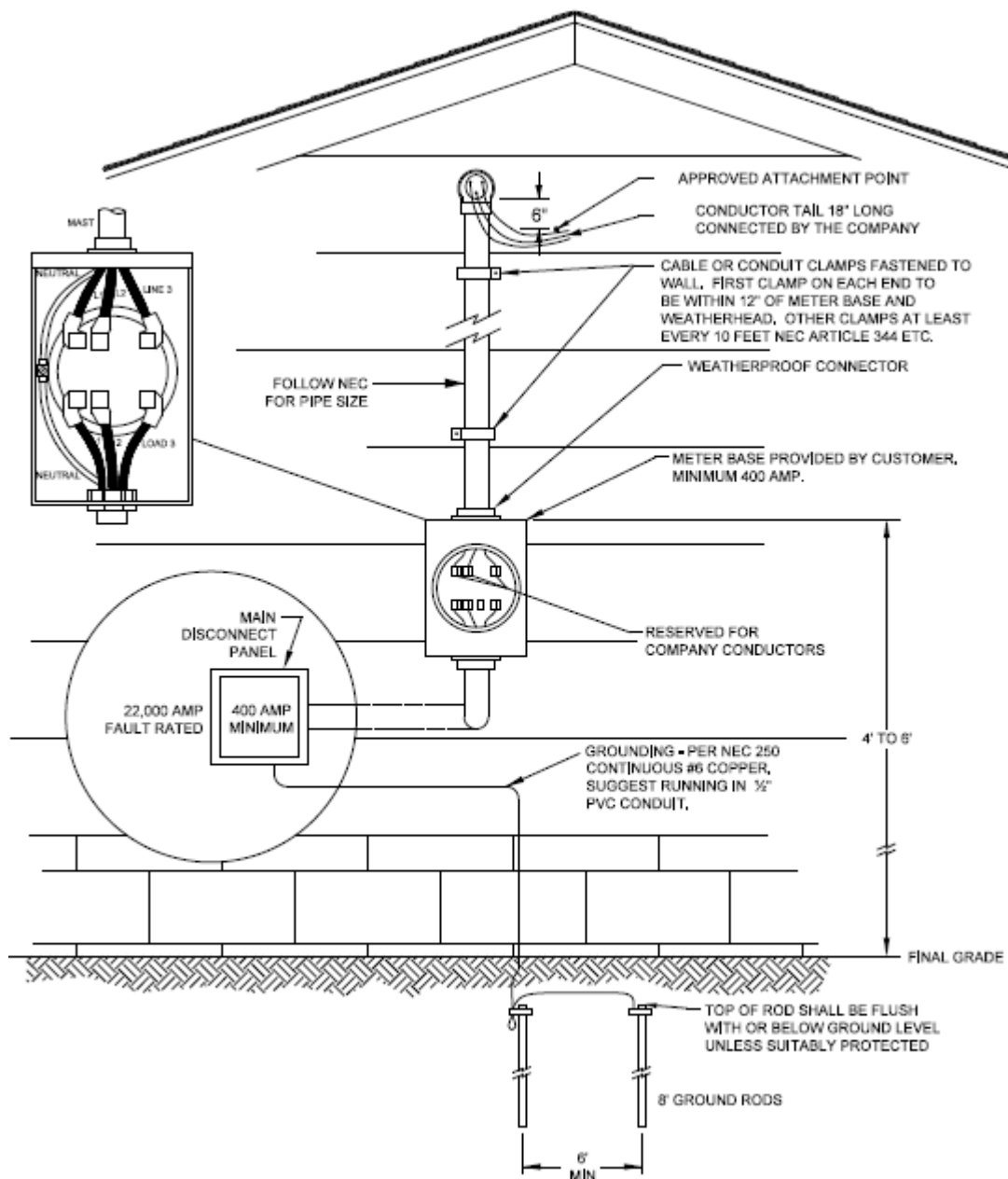

5-3 400A – 3000A Three-Phase Overhead – CT Metered

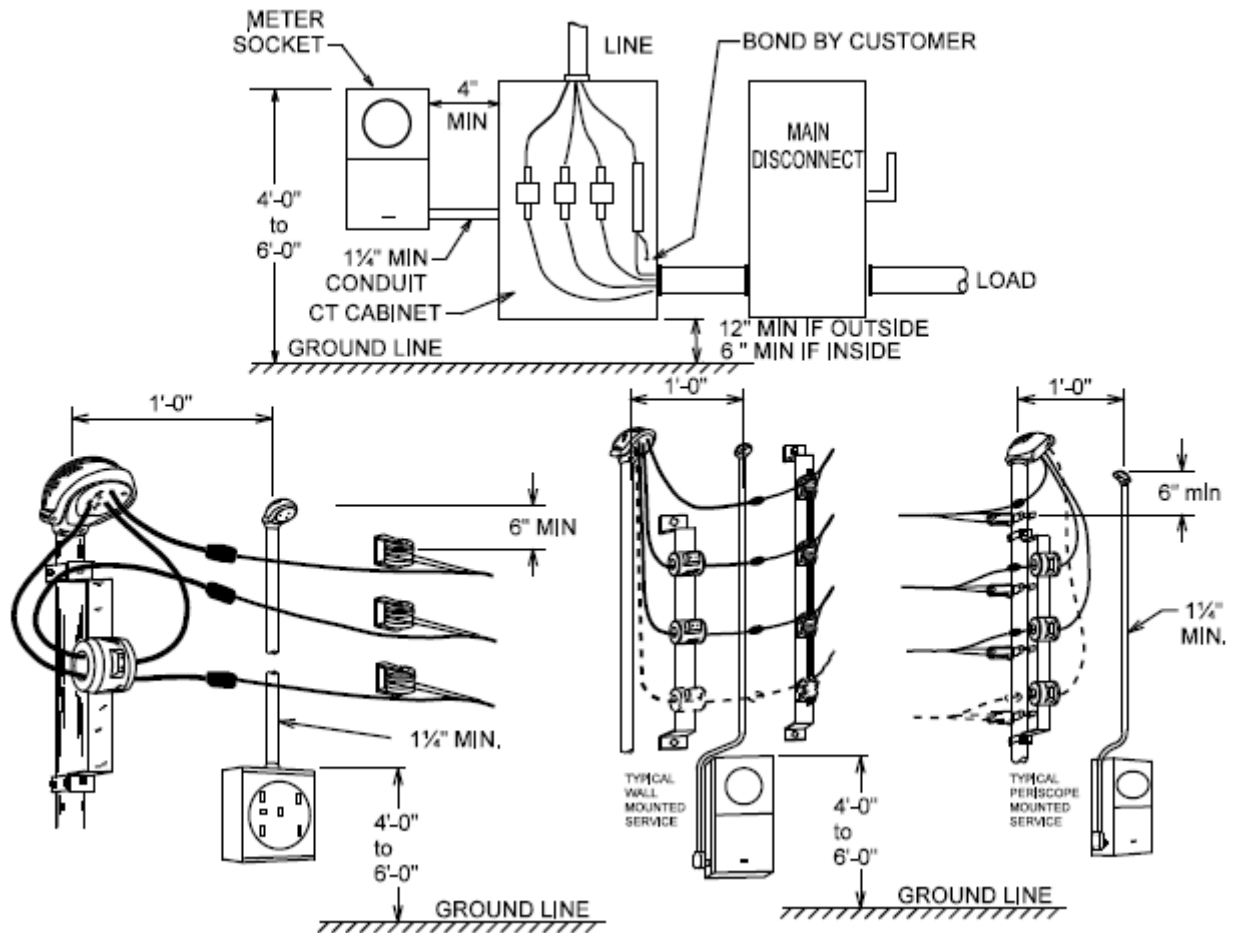

Notes:

1. Because of code clearance issues, the location of customer's service entrance and meter equipment shall, in all cases, be designated by the Company.
2. The customer shall furnish and install the meter socket, conduit to the meter socket and the CT cabinet, if applicable. The Company will provide the CT mounting bracket for periscope installation. The Company will mount the CT mounting bracket. The Company will supply the CTs, meter and meter wiring (including the meter socket ground).
3. The CT cabinet must be bonded per NEC 250.102. See Subsection 5-6 on bonding requirements.
4. Consult the Company for CT cabinet bonding requirements on three-wire 240 volt three-phase and three-wire 480 volt three-phase installations.
5. The connections to the Company's service drop shall be made by the Company.
6. In four-wire 120/240 three-phase installations, the wild leg shall be identified with orange tape or other acceptable means.
7. The length of the service entrance conductors protruding from the weather head shall be at least 18 inches.
8. Periscopes shall be back-guyed if used for dead ending the service drop.
9. See Subsection Appendix B for Fault Current information.
10. See Subsection 5-6 for approved list of CT cabinets.
11. To be used only with Regional Engineering approval.

5-4 200A – 320A Three-Phase Underground

Specifications:

- Ringless Type Meter Socket
- 320A Continuous, 400A Max
- Rated 600V AC
- 3 Phase, 4-Wire
- UL Listed
- 7 Jaw Meter Socket
- Bypass Lever
- Sealable
- No cover over meter

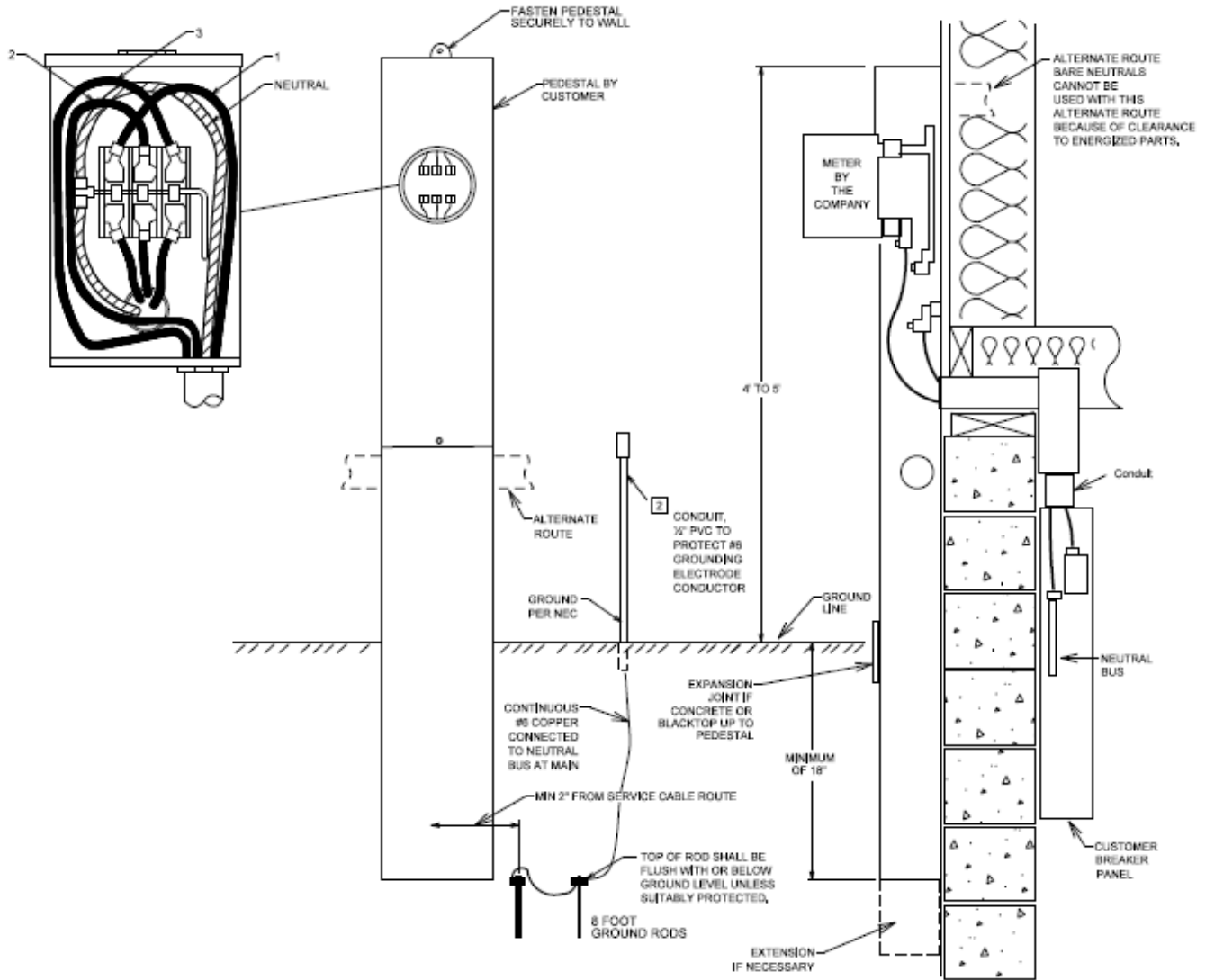

5-5 400A – 3000A Underground - CT Metered in Pad mounted Transformer

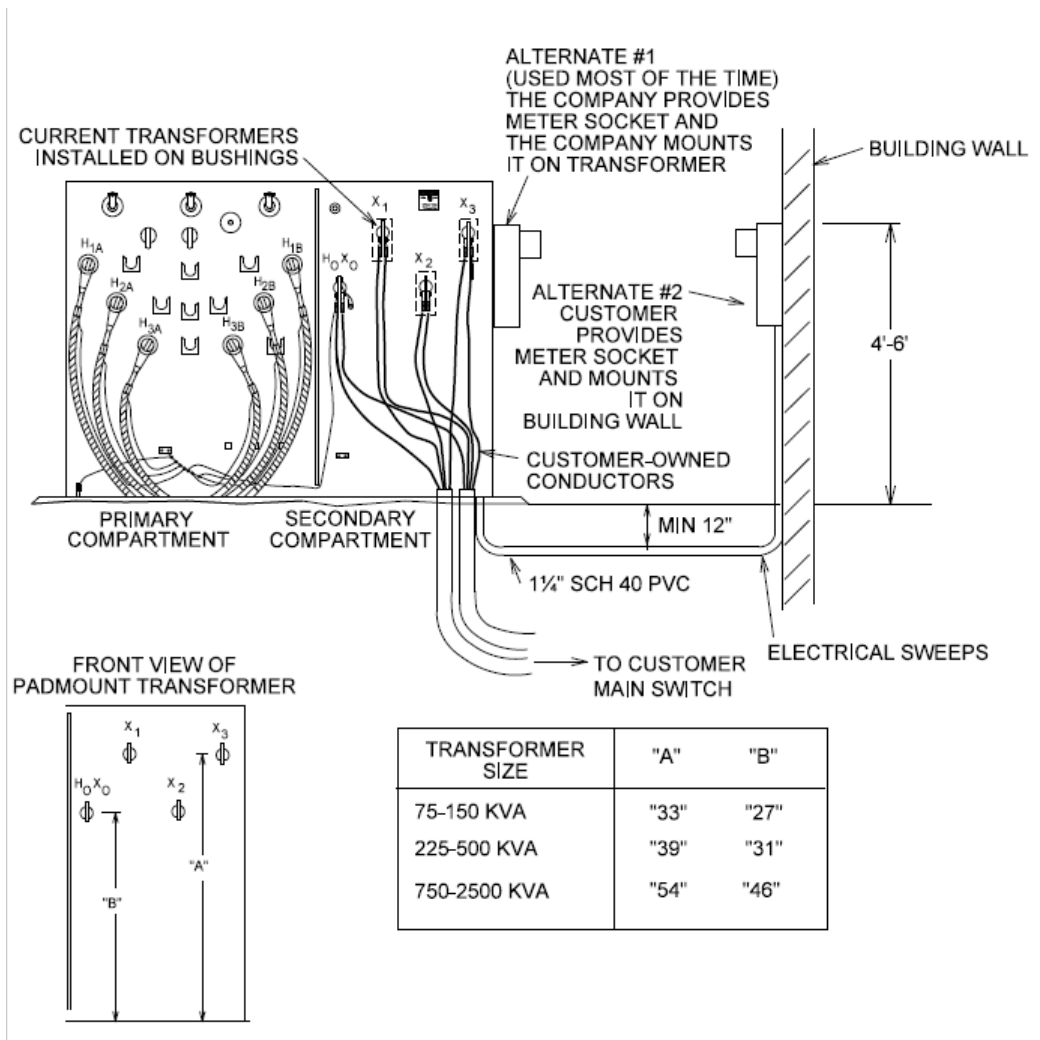

Notes:

1. **Approval must be obtained from the Company to use this metering option.** It is only available from dedicated (no other customers possible) three-phase pad mounted transformers. **The service size must be 800 amp or larger.** With Company approval, however, 277/480 can get down to 400 amp. The service can only be run to one building, assumed that UPPCO will not want allowed to more than one building. Code in MI will allow.
2. The customer shall own, install and maintain the service. The Company will terminate the transformer end of the customer service conductors, if possible. Let the Company know the size and number of service conductors.
3. The above drawing is a diagram showing the metering. See Subsection 5-11 for details on pad mount setting.
4. The meter socket will be provided by the Company at cost where it is mounted on the pad mount transformer. If it is installed on the building wall, it will be provided by the customer and installed by the customer. The maximum distance between the pad mount and the building-mounted meter socket is 25 feet.
5. Mounting the meter socket on a free-standing pedestal is not acceptable.
6. The Company will ground the meter socket.
7. **The customer equipment grounding bond cannot occur in the pad mount transformer per NEC 250.24(A)(1).**

Instrument Transformer-Rated Meter Sockets (for CT Installations)
13 Terminal for 120/208 & 277/480 (Co. stock #136-1160)

| Manufacturer | |
|--------------------|-------------------------|
| Schneider Electric | TSS13-HO-SR1, USTS13-2B |
| Meter Devices | 3040A-13 |
| Milbank | UC7449-XL |
| Erickson | W-340 |
| Talon (Siemens) | 9837-8503 |
| Durham | USTS13-2B |
| Cutler Hammer | USTS13-2B-CH |
| Midwest | USTS13-2B-MEP |

5-6 400A – 3000A Underground - CT Metered in CT Cabinet

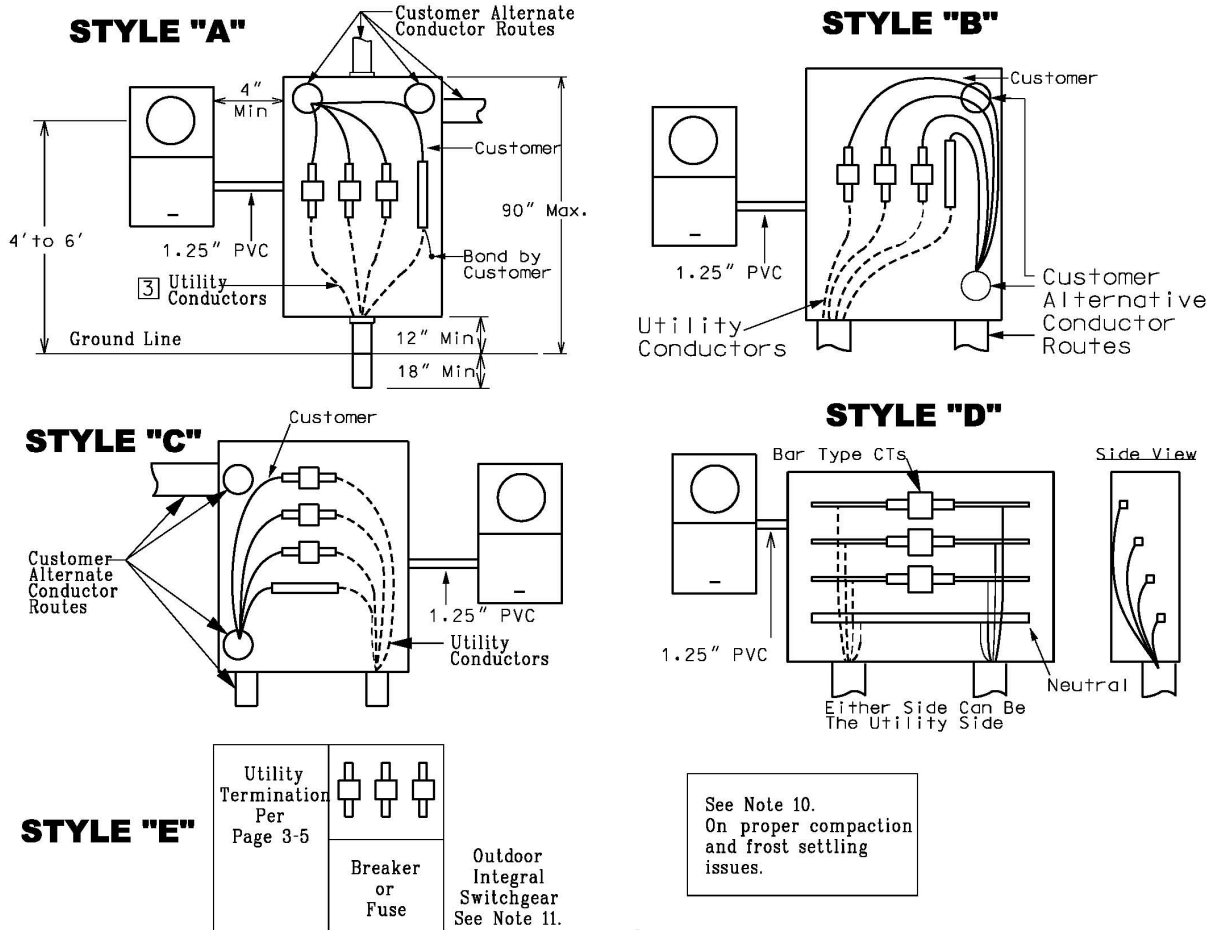

★See CT Cabinets Table on Subsection 3-4

□ Notes:

1. The customer provides the CT cabinet and meter socket.
2. The CT cabinet shall be mounted outside.
3. **Note the location of the customer and utility conductor terminations as shown above. The Company cannot terminate its conductors in any other location. Consult the Company with any questions.**
4. The Company requires that all main disconnects rated over 400 Amp be provided with a means of locking the disconnect in the open position. This meets the MIOSHA Rule 408.14004 lock-out procedure.
5. CT metering is required for 600 amp single phase and 600 amp 120/208 three phase. CT metering is required for 800 amp single phase, 800 amp and larger 120/208 three phase, and 400 amp and larger 277/480 three phase. With CT metering, there are several options. They are the use of the CT cabinet, CTs in the pad mount transformer (see Subsection 5-5) or CTs in the switchgear (also see Subsection 5-7) or overhead CT metering (see Subsection 5-8).
6. The CT cabinet must be bonded per NEC 250.102. See Bonding Table. Consult the Company for CT cabinet bonding requirements on three wire 240 volt three phase and three wire 480 volt three phase installations.
7. In four wire 120/240 three phase installations, the wild leg shall be identified with orange tape or other acceptable means.
8. See Subsection Appendix B on Fault Current information.
9. Minimum clear space in front of the cabinet and/or meter shall be 2 feet beyond the cover in the extended position or a minimum of 3 feet, whichever is greater.
10. The Company may require conduit for services under driveways and parking lots.
11. Because of settling problems, it is necessary for the customer to provide adequate compaction for disturbed soils below 30 inches. This is soil below the normal underground service burial depth. This needs to be done with sand or gravel. Frozen material and non-compacted clay are not acceptable. See also NEC 300.5(J).
12. Integral switchgear installations, similar to Style "E", need to be approved by the Company, if not already on the approved list. These installations need to be capable of accommodating an ABB Type CLC window current transformer. The switchgear manufacturer provides the bus bar and CT support with the switchgear.
13. The meter socket cannot be mounted to the CT cabinet door.

Instrument Transformer-Rated Meter Sockets (for CT installations)

UPPCO SERVICE MANUAL

Revised 6/2022

Section 5 THREE-PHASE METERING

Page 8 of 20

“AA” 13 Terminal for 120/208, 277/480, & 120/240 4-wire three phase.

“BB” 8 Terminal for 240 3-wire & 480 3-wire three phase (not Std.).

| Manufacturer | “AA” | “BB” |
|--------------------|---------------|-------------|
| Square D (Anchor) | TSS13-HO-SR1 | TSS8-HO-SR1 |
| Meter Devices | 3040A-13 | 3040A-8 |
| Milbank | UC7449-XL | UC7448-XL |
| Erickson | W-340 | W-330 |
| Talon (Siemens) | 9837-8503 | 9837-8403 |
| Durham | USTS13-2B | |
| Cutler Hammer | USTS13-2B-CH | |
| Midwest | USTS13-2B-MEP | |
| Schneider Electric | USTS13-2B | |

Current Transformer Cabinets

- Style of cabinet
- “A” With CTs mounted vertically, bottom in & top out
 - “B” with CTs mounted vertically, bottom in & top or bottom out
 - “C” With CTs mounted horizontally
 - “D” Stepped termination style with CTs horizontal
 - “E” Integral switchgear

Galva Closure also goes by RJB.

EMI stands for Electro-Mechanical Industries

AMP stands for American Midwest Power

| 400 AMP CT | Style Cabinet | Manufacturer | Catalog # | Dimensions (") | Fault Rating | Conduit | |
|------------|----------------|---------------|--------------------|--------------------|-----------------|-------------------------|-------------------------|
| 3-Wire | A | Erickson | WE-182-4 | 45.5x20x7.25 | 42,000 | 1-3" | |
| | A | Galva-Closure | UPP-403UG | 42x20x8.5 | 65,000 | | |
| | A & B | Galva-Closure | UPP-403UGBX | 48x25x15 | 65,000 | | |
| | A | EMI | CTB146-WPS | 48x30x10 | 65,000 | | |
| | B | AMP | WPST4-3TM | 48x36x15 | 85,000 | | |
| 4-Wire | D | AMP | WPSSB8-3ACT | 60x33x13 | 65,000 | | |
| | A | Erickson | WE-182-5 | 45.5x20x7.25 | 42,000 | 1-3" | |
| | A | Galva-Closure | UPP-404UG | 42x20x8.5 | 65,000 | | |
| | A & B | Galva-Closure | UPP-404UGBX | 48x25x15 | 65,000 | | |
| | A | EMI | CTB346-WPS | 48x30x10 | 65,000 | | |
| 600 AMP CT | B | AMP | WPST4-4TM | 48x36x15 | 85,000 | | |
| | D | AMP | WPSSB8-4ACT | 60x33x13 | 65,000 | | |
| | Cabinet | | | | | | |
| | 3-Wire | A | Erickson | WE283-4-USG | 48x48x11 | 65,000 | 2 – 3" or 1 – 6" |
| | | A | Galva-Closure | UPP-603UG | 54x36x13 | 65,000 | |
| C | | Galva-Closure | UPP-603UGBX | 48x46x13 | 65,000 | | |
| A | | EMI | CTB146-WPS | 48x30x10 | 65,000 | | |
| D | | AMP | WPSSB8-3ACT | 60x33x12 | 65,000 | | |
| 4-Wire | B | AMP | WPST68-3TM | 48x36x15 | 85,000 | | |
| | A | Erickson | WE283-5-USG | 48x48x11 | 65,000 | 2 – 3" or 1 – 6" | |
| | A | Galva-Closure | UPP-604UG | 54x36x13 | 65,000 | | |
| | C | Galva-Closure | UPP-604UGBX | 48x46x13 | 65,000 | | |
| | A | EMI | CTB346-WPS | 48x30x10 | 65,000 | | |
| 800 AMP CT | D | AMP | WPSSB8-4ACT | 60x33x13 | 65,000 | | |
| | B | AMP | WPST68-4TM | 48x36x15 | 85,000 | | |
| | Cabinet | | | | | | |
| | 3-Wire | A | Erickson | CUCT-83 | 48x48x11 | 65,000 | 2-4" |
| | | A | Galva-Closure | UPP-803UG | 54x36x13 | 65,000 | |
| C | | Galva-Closure | UPP-803UGBX | 48x46x13 | 65,000 | | |
| A | | EMI | CTB180-WPS | 60x34x18 | 65,000 | | |
| D | | AMP | WPSSB8-3ACT | 60x33x13 | 65,000 | | |
| 4-Wire | B | AMP | WPST68-3TM | 48x36x15 | 85,000 | | |
| | A | Erickson | CUCT-84 | 48x48x11 | 65,000 | 2-4" | |
| | A | Galva-Closure | UPP-804UG | 54x36x13 | 65,000 | | |
| | C | Galva-Closure | UPP-804UGBX | 48x46x13 | 65,000 | | |
| | A | EMI | CTB380-WPS | 60x34x12 | 65,000 | | |
| | D | AMP | WPSSB8-4ACT | 60x33x13 | 65,000 | | |
| | B | AMP | WPST68-4TM | 48x36x15 | 85,000 | | |

UPPCO SERVICE MANUAL

Revised 6/2022

Section 5 THREE-PHASE METERING

Page 9 of 20

| 1000 & 1200 AMP CT | Style Cabinet | Manufacturer | Catalog # | Dimensions (") | Fault Rating | Conduit |
|----------------------|----------------|---------------|-------------|----------------|--------------|---------|
| 4-Wire | A or B | EMI | CTB312WPS | 66x42x16 | 65,000 | 3-4" |
| | C | Erickson | CUCT-124WPS | 60x51x15 | 85,000 | |
| | C | Galva-Closure | UPP-1204UG | 48x45.75x13 | 85,000 | |
| | A | AMP | WPSCT12-4TM | 60x36x15 | 85,000 | |
| 1600 AMP CT | Cabinet | | | | | |
| 4-Wire | A or B | EMI | CTB316WPS | 72x46x18 | 65,000 | 4-4" |
| | C | Erickson | UCT-164WPS | 60x60x15 | 85,000 | |
| | C | Galva-Closure | UPP-1604UG | 60x60x15 | 85,000 | |
| | A | AMP | WPSCT16-4TM | 75x39x24 | 85,000 | |
| * 2000 AMP CT | Cabinet | | | | | |
| 4-Wire | C | Galva-Closure | UPP-2004UG | 60x60x15 | 85,000 | 6-4" |
| | C | Erickson | CT204SG-WPS | 60x66.5x15 | 100,000 | |

* CT cabinets rated at 2000 Amp and higher shall accommodate split bar configuration CT's.

Pedestal Raceways for CT Cabinets

(Alternate to Conduit Riser for Utility Conductors)

| Length | Erickson 600/800 Amp | Galva-Closure 600/800 Amp |
|--------|-------------------------|------------------------------|
| 36" | USR-36 | CC-36 |
| 48" | USR-48 | CC-48 |
| 60" | USR-60 | CC-60 |

AMP also makes pedestal raceways in varying sizes and lengths. This is under the WWPB catalog series.

Bonding Table

| Size of Largest Service Entrance Conductor or Equivalent Area For Parallel Conductors | | Bonding Jumper | |
|--|-------------------------------|--------------------|-----------------------|
| Copper | Aluminum | Copper | Aluminum Conductor |
| #2 or smaller | 1/0 or smaller | #8 or 16.51 kcmil | #6 |
| #1 or 1/0 | 2/0 or 3/0 | #6 or 26.24 kcmil | #4 |
| 2/0 or 3/0 | 4/0 or 250 kcmil | #4 or 41.74 kcmil | #2 |
| Over 3/0 – 350 kcmil | Over 250 kcmil – 500 kcmil | #2 or 66.36 kcmil | 1/0 |
| Over 350 kcmil – 600 kcmil | Over 500 kcmil – 900 kcmil | 1/0 or 105.6 kcmil | 3/0 |
| Over 600 kcmil – 1100 kcmil | Over 900 kcmil – 1750 kcmil | 2/0 or 133.1 kcmil | 4/0 |
| Over 1100 kcmil – 1300 kcmil | Over 1750 kcmil – 2000 kcmil | 3/0 or 167.8 kcmil | 250 |
| Over 1300 kcmil – 1700 kcmil | Over 2000 kcmil – 2400 kcmil | 4/0 or 211.6 kcmil | 300 |
| Over 1700 kcmil – 2000 kcmil | Over 2400 kcmil – 2800 kcmil | 250 kcmil | 350 |
| Over 2000 kcmil – 2800 kcmil | Over 2800 kcmil – 4000 kcmil | 350 kcmil | 500 |
| Over 2800 kcmil – 4000 kcmil | Over 4000 kcmil – 6000 kcmil | 500 kcmil | 750 |
| Over 4000 kcmil – 6000 kcmil | Over 6000 kcmil – 10000 kcmil | 750 kcmil | 1250 |

Equipment Bond – supply side of Service and Main Bonding Jumper (CT Cabinets)

Table 250.66

NEC 250.96, NEC 250.102 and NEC 250.142

It is not necessary to run the bond from the CT cabinet back to the service disconnect if the CT cabinet is located on the supply side of the disconnect.

5-7 Space Required to Terminate in Service Entrance Panels & Switchgear

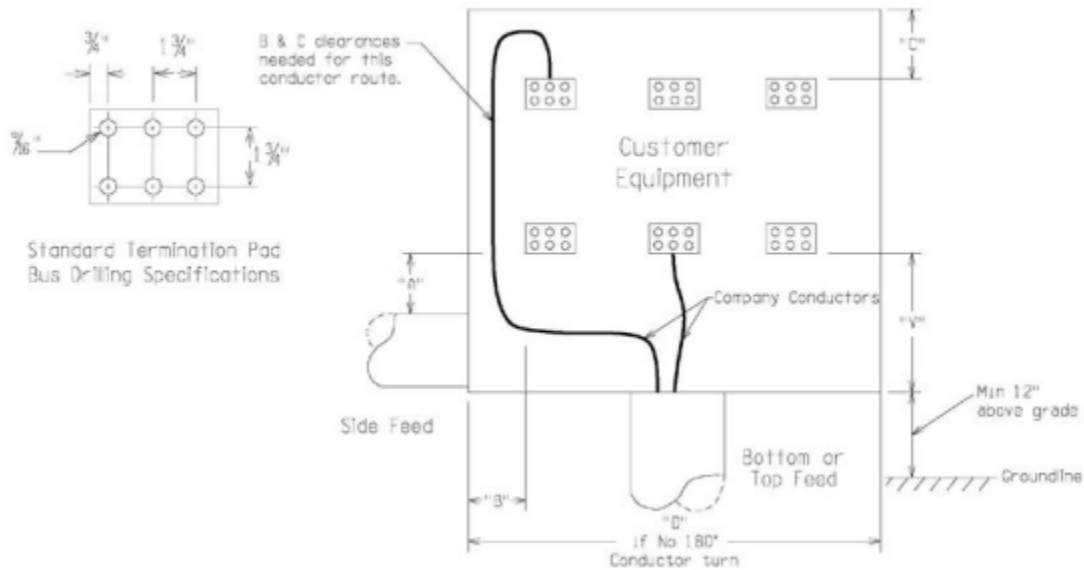

Table 1 - Standard Conductor and Conduit Sizes

| Switchgear (Amps) | Phases | No. & Size Conductors Per Phase Aluminum | No. Conduits and Size (in.) | "V" | "A" | "B" | "C" | "D" |
|-------------------|--------|--|-----------------------------|-----|------|-----|------|-----|
| | | | Conduit Run | | | | | |
| 200 | 1 | 1-3/0 | 1-2" | 12" | 6.5" | 4" | 6.5" | 8" |
| 200 | 3 | 1-3/0 | 1-3" | 12" | 6.5" | 4" | 6.5" | 10" |
| 400 (320a) | 1 | 1-350 | 1-3" | 18" | 12" | 5" | 12" | 9" |
| 400 | 3 | 1-350 | 1-3" | 18" | 12" | 5" | 12" | 11" |
| 600 | 1 | 2-350 | 2-3" | 18" | 18" | 8" | 16" | 10" |
| 600 | 3 | 2-350 | 2-3" | 18" | 18" | 8" | 16" | 12" |
| 800 | 1 | 2-700+ | 2-4" | 24" | 24" | 10" | 18" | 15" |
| 800 | 3 | 2-700+ | 2-4" | 24" | 24" | 10" | 18" | 19" |
| 1000 | 3 | 3-700+ | 3-4" | 30" | 30" | 14" | 22" | 35" |
| 1200 | 3 | 3-700+ | 3-4" | 30" | 30" | 14" | 22" | 35" |
| 1600 | 3 | 4-700+ | 4-4" | 36" | 36" | - | - | 40" |
| 2000 | 3 | 6-700+ | 6-4" | 42" | 42" | - | - | 40" |
| 2500 | 3 | 7-700+ | 7-4" | 42" | 42" | - | - | 40" |
| 3000 | 3 | 8-700+ | 8-4" | 42" | 42" | - | - | 40" |

+Std. is 350 neutral

Notes:

1. This page deals exclusively with Company conductors. Consult the Company when planning switchgear installations.
2. The Company uses 90°C conductor; therefore, the Company cannot terminate on customer main disconnects. (NEC 110.14)

UPPCO SERVICE MANUAL

Revised 6/2022

Section 5 THREE-PHASE METERING

Page 11 of
20

3. "V" dimension for 3/0 and 350 comes from NEC Table 312.6(B).
4. "B" dimension based on NEC 312.6(A). "C" dimension based on NEC 312.6(B). 180 degree cable bends are only allowed by the Company through 600 Amp. Consult the Company if you have such a situation with a larger entrance.
5. If these minimum termination dimensions cannot be met, it may be necessary to use a separate termination enclosure per Subsection 5-8.
6. This table gives standard Company conductor sizes. Customers must size their service entrance conductor based on the NEC. Note things such as Table 310.16 on general conductor ampacities, Table 310.15(B)(2)(a) on derating for more than three current-carrying cables in a raceway, duct configurations for over 2KV cables in Figure 310.60, Article 376 and 378 on raceway fill, etc.
7. Consult the Company when planning 2000 Amp and larger switchgear.
8. "D" Dimension based on terminator widths and 1" phase spacing. This applies only to single direction termination. If some conductors must turn a 180 degree to terminate, add dimension "B" as necessary.
9. One additional conduit shall be required where potential problems may occur under blacktop, concrete, or building structure. Additional considerations shall be given for rocky conditions.
10. 3" acceptable if 320A pedestal.
11. Any variance of the conductor sizes above will need Regional Engineering approval.
 - a. Parallel 350MCM can be used in substitution of the 700MCM depending on availability.

5-8 Termination Enclosures

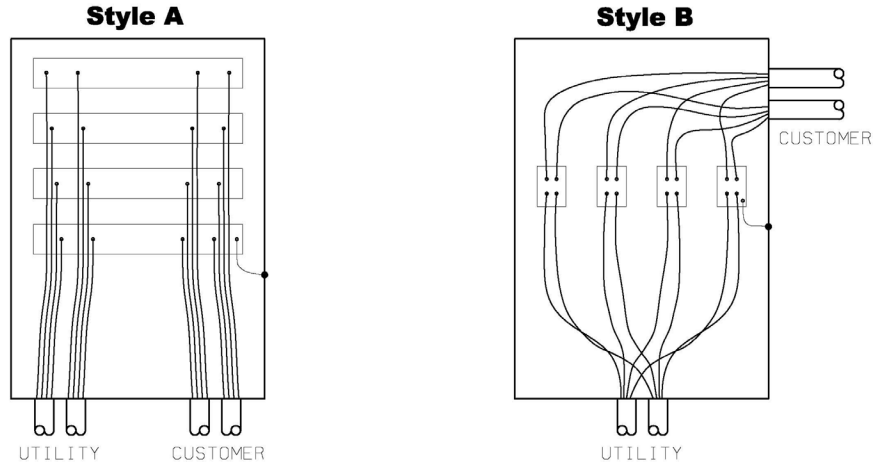

The above termination enclosures are options for certain wiring installations. Consult the Company before using these options.

Type A has horizontal bus bars that are stacked at different distances from the back of the cabinet in order to provide enough room to terminate (the top phase is the farthest from the back of the cabinet). The neutral is the bottom bus bar.

Type B has vertical bus bar and conductor training.

| Amps | | Type | Mfg | Catalog # | Dimensions (") |
|-------------|--------|-------------|---------------|------------------|-----------------------|
| 400 amp | 3-wire | B | Erickson | TB-365N | 42.25x20x7.25 |
| | | A | Galva-Closure | TBBXWPS-413-1 | 48x25x15 |
| | | B | Galva-Closure | TB-413-1 | 42x20x8.5 |
| | | A | AMP | WPSSB8-3A | 60x33x13 |
| | | B | AMP | WPSTB4-3A | 40x24x9 |
| | 4-wire | B | Erickson | TB-465N | 42.25x20x7.25 |
| | | A | Galva-Closure | TBBXWPS-434-1 | 48x25x15 |
| | | B | Galva-Closure | TB-434-1 | 42x20x8.5 |
| | | A | AMP | WPSSB8-4A | 60x33x13 |
| | | B | AMP | WPSTB4-4A | 40x24x9 |
| 800 amp | 3-wire | B | Erickson | TB-367N | 56x42x11 |
| | | A | Galva-Closure | TBBXWPS-813-3 | 48x36x15 |
| | | B | Galva-Closure | TB-813-2 | 48x26x11 |
| | | A | AMP | WPSCSB8-3A * | 60x33x13 |
| | | B | AMP | WPSCTB8-3A * | 60x33x13 |
| | 4-wire | B | Erickson | TB-467N | 56x42x11 |
| | | A | Galva-Closure | TBBXWPS-834-3 | 48x36x15 |
| | | B | Galva-Closure | TB-834-2 | 48x26x11 |
| | | A | AMP | WPSSB8-4A * | 60x33x13 |
| | | B | AMP | WPSTB8-4A * | 60x33x13 |
| 1200 amp | 4-wire | B | Erickson | TB-468N | 60x36x15 |
| | | A | Galva-Closure | TBBXWPS-1234-5 | 54x46x15 |
| | | B | Galva-Closure | TB-1234-4 | 54x36x15 |
| | | A | AMP | WPSSB12-4A * | 60x33x13 |
| | | B | AMP | WPSTB12-4A * | 60x33x13 |
| 1600 amp | 4-wire | B | Erickson | TB-469N | 60x40x15 |
| | | A | Galva-Closure | TBBXWPS-1634-4 | 54x46x15 |
| | | B | Galva-Closure | TB-1634-5 | 60x38x17 |
| | | A | AMP | WPSSB16-4A * | 60x33x13 |
| | | B | AMP | WPSTB16-4A * | 60x33x13 |
| 2000 amp | 4-wire | B | Erickson | TB-4610N | 78.25x44x20.75 |
| | | A | Galva-Closure | TBBXWPS-2034-5 | 66x54x15 |
| | | B | Galva-Closure | TB-2034-6 | 72x42x21 |
| | | A | AMP | WPSSB20-4A * | 60x33x13 |
| | | B | AMP | WPSTB20-4A * | 60x33x13 |
| Amps | | Type | Mfg | Catalog # | Dimensions (") |
| 2500 amp | 4-wire | A | Galva-Closure | TBBXWPS-2534-7 | 72x50x21 |

UPPCO SERVICE MANUAL

| | | |
|----------------|---------------------------------------|---------------|
| Revised 6/2022 | Section 5 THREE-PHASE METERING | Page 13 of 20 |
|----------------|---------------------------------------|---------------|

| | | | | | |
|----------|--------|---|---------------|----------------|----------|
| | | B | Galva-Closure | TB-2534-7 | 72x42x21 |
| | | A | AMP | WPSTC25- * | 60x51x39 |
| 3000 amp | 4-wire | A | Galva-Closure | TBBXWPS-3034-8 | 72x50x21 |
| | | B | Galva-Closure | TB-3034-8 | 72x42x21 |

See Subsection 5-6 for bonding requirements between the neutral and the termination enclosure. Because of settling problems, it is necessary to provide adequate compaction under the normal UG service conductor depth (30") for disturbed soils. This needs to be done with sand or gravel. Frozen material and uncompacted clay are not acceptable.

5-9 Large CT Installation, Bus Bars – 2500 - 3000 Amp – Metering in Switchgear

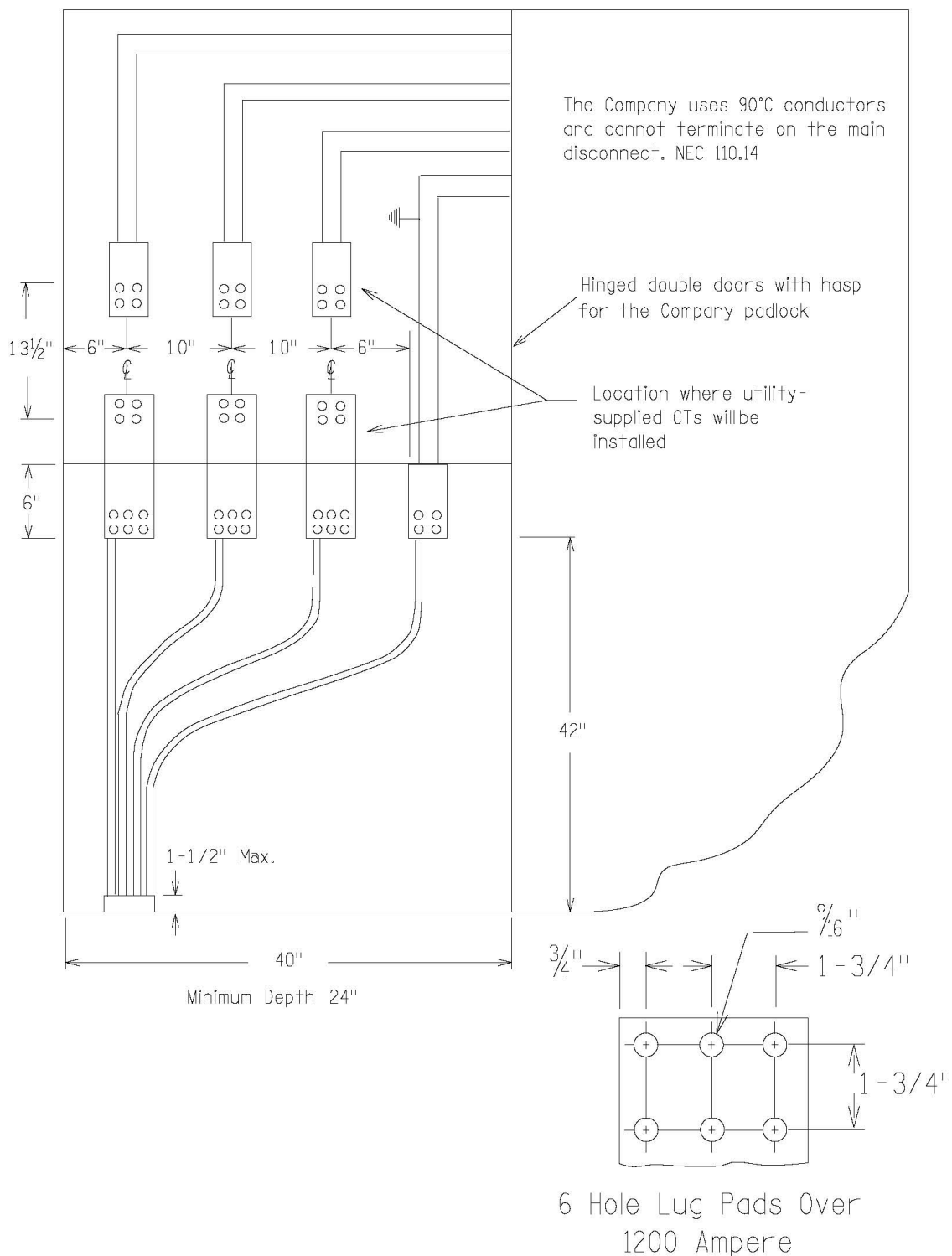

Contact the Company for approval on these installations.

Instrument meter socket to be located outside and within 25 feet of CT cabinet. The conduit between the meter socket and CT cabinet shall be min. 1-1/4" diameter.

5-10 Large CT Installation, Doughnuts – 2500 - 3000 Amp – Metering in Switchgear

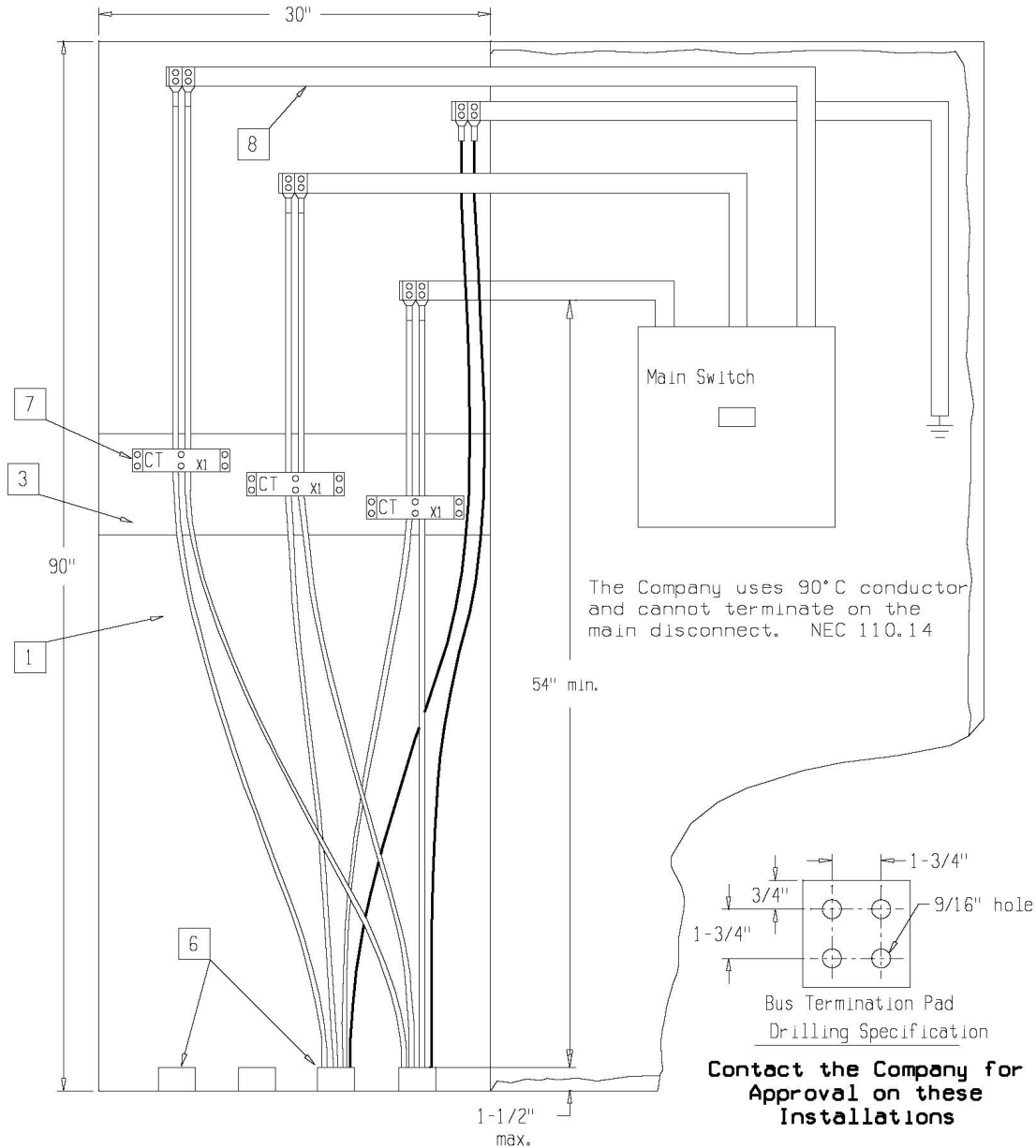

□ Notes:

1. Depth of current transformer compartment shall be 24" minimum.
2. CT compartment shall have hinged door and locking hasp.
3. CT mounting bracket must be adjustable for depth and height.
4. For top feed, reverse diagram configuration.
5. Customer shall furnish detailed drawings for Company approval before equipment is ordered.
6. Check with the Company to determine how many conductors per phase will be used and how many holes will be needed on the termination pad.
7. CT's shall be located approximately 18" below bus.
8. Bus shall be adequately braced to support conductors.
9. Instrument meter socket to be located outside and within 25 feet of CT cabinet. The conduit between shall be minimum 1-1/4 inch.

| | | |
|-----------------------------|---------------------------------------|------------------|
| UPPCO SERVICE MANUAL | | |
| Revised 6/2022 | Section 5 THREE-PHASE METERING | Page 16 of 20 |

5-11 Standard Pad for 75 - 2500 KVA Pad mount Transformers

1. See Section 2-4 for required clearances.
2. A pre-cast option is available from the Company.
3. For customer-poured pads, a minimum cure time of 7 days is required before setting a transformer.
4. Require dimensions of 8'6" x 7' x 6" thick with a (minimum of) 3/8" re-bar reinforcement grid, spaced 1' on-center. See diagram below.
5. Finished surface of the transformer pad shall 4" – 6" above finished grade.
6. Service conduits shall always start from the front right corner of the window and tight to each other and in numbered order. See Section 5-7 for the number and size of the conduits if the Company is providing the service conductors. Install the conduits to extend a minimum of one foot beyond the edge of the pad.
7. The primary conduits shall start from the front left corner of the window and shall be positioned next to each other. There shall be two six-inch conduits. Install the conduits to extend a minimum of one foot beyond the edge of the pad.
8. All conduits shall not extend more than 3" from the pad surface per NEC 408.5
9. Soil conditions dictate whether a gravel base or concrete footings are required
 - a. If undisturbed soil capable of carrying weight is encountered within 3' of excavation, a tamped class 5 gravel base can be utilized.
 - b. Alternatively, 8" sonotubes extending 4' can be utilized. See diagram below for placement.
10. Concrete shall have a minimum strength of 3000# per sq. inch and contain not less than a 6 bag mix per cubic yard. A maximum of one bag of fly ash may be substituted for one bag of cement per cubic yard of concrete.
11. Approximate weights on transformers are 75 kVA (2300#), 500 kVA (6000#), 750 kVA (8400#), 2500 kVA (17000#).
12. Alternate dimensions of 6'6" x 5'0" can be used with Company approval.

UPPCO SERVICE MANUAL

Revised 6/2022

Section 5 THREE-PHASE METERING

Page 17 of 20

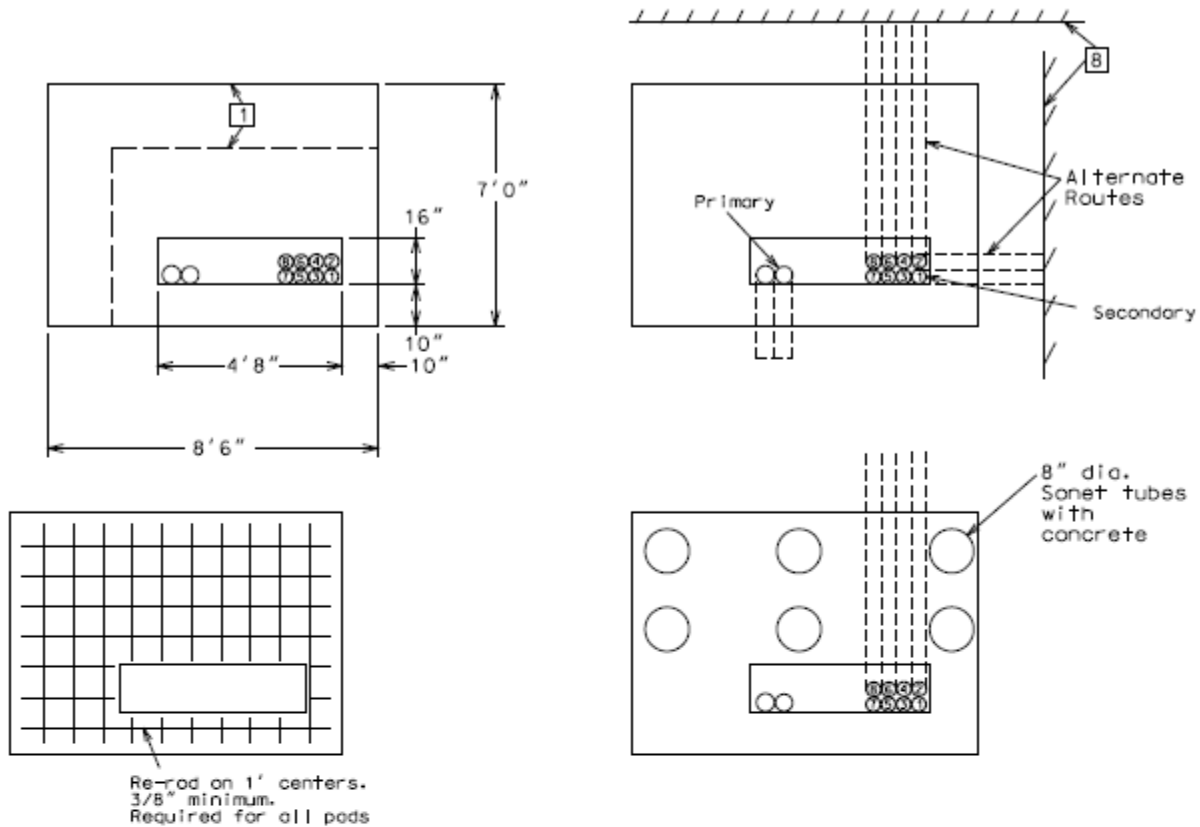

Gravel Base Alternative

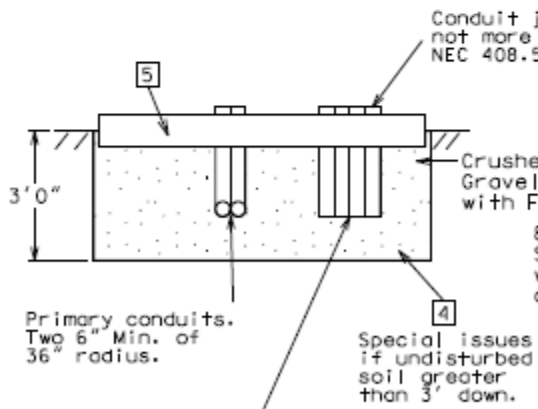

See Section 2-6 for size and number of conduits. Min. of 36" radius.

Concrete Footing Alternative

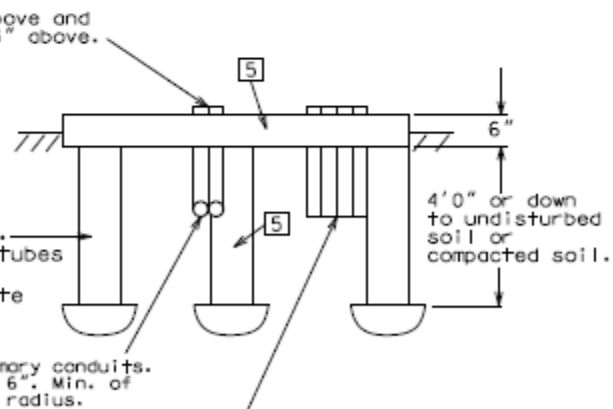

See section 2-6 for size and number of conduits. Min. of 36" radius.

5-12 Large Concrete Pad for 3750 - 5000 KVA Pad mount Transformers

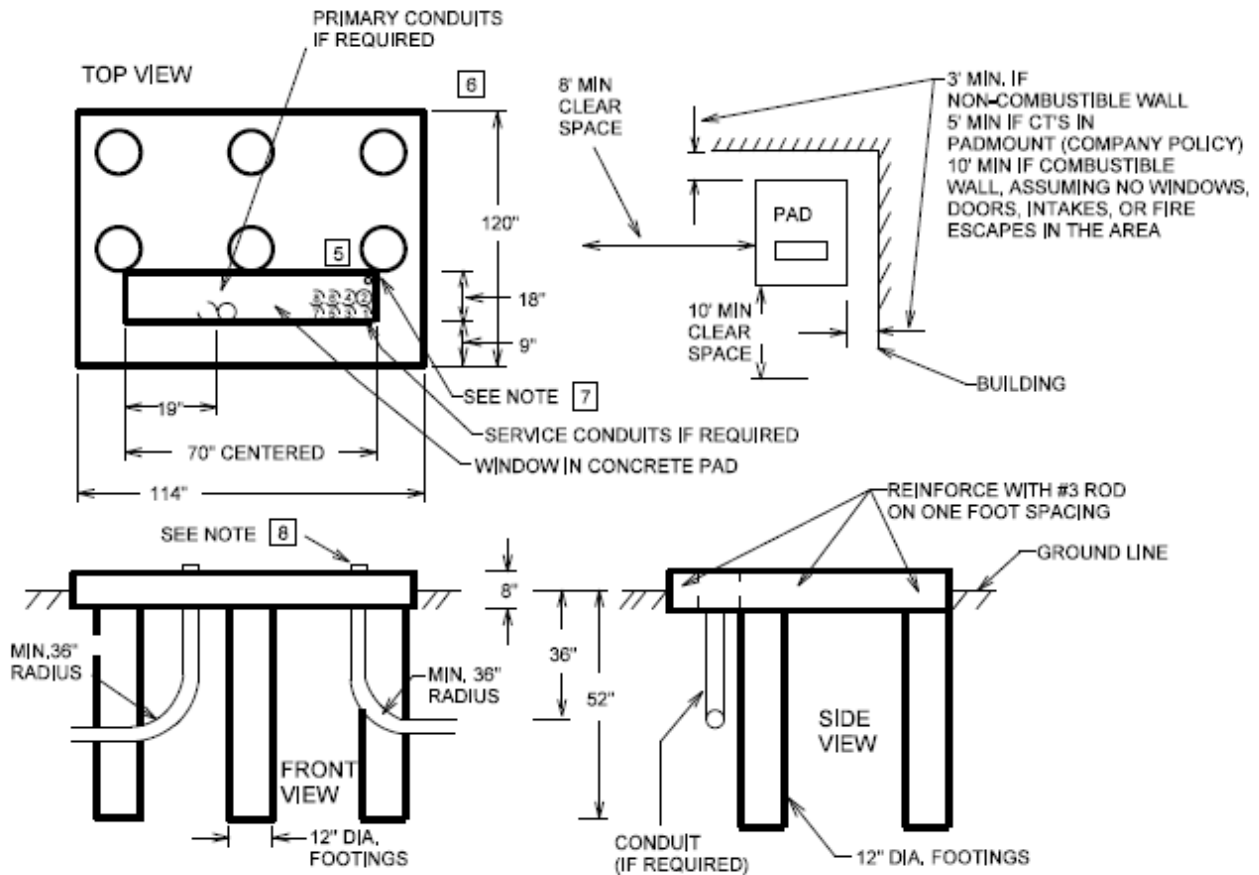

Notes:

1. Concrete shall have a minimum strength of 3000 lbs. per sq. inch and contain not less than 6 bags of cement per cubic yard. Approximately one bag of fly ash may be substituted for one bag of cement per cubic yard of concrete.
2. The top of the pad shall be reinforced with #3 rods on a one-foot spacing.
3. These transformers range from 20,000 to 28,000 lbs.
4. Service conduits shall always start from the front right corner of the window. The conduits must be positioned tight to the right side of the window and tight to each other and in numbered order. This is so that the conduits don't cross over into the primary side of the transformer.
5. Position primary conduits in the front of the window and 19 inches from the left side (see top view, above). Use two each, six inch conduits.
6. 1-1/4" PVC meter conduit to building wall, if required. End this 3 inches above pad.
7. Service and Primary conduits to be just above (max. 3") pad.
8. Concrete is considered fully cured in 21 days. However, the majority of the strength is obtained after 7 days. If transformers will be set in fewer than 7 days, cement should be tested to be sure it has at least 2500#/sq. in. of strength.

UPPCO SERVICE MANUAL

Revised 6/2022

Section 5 THREE-PHASE METERING

Page 19 of 20

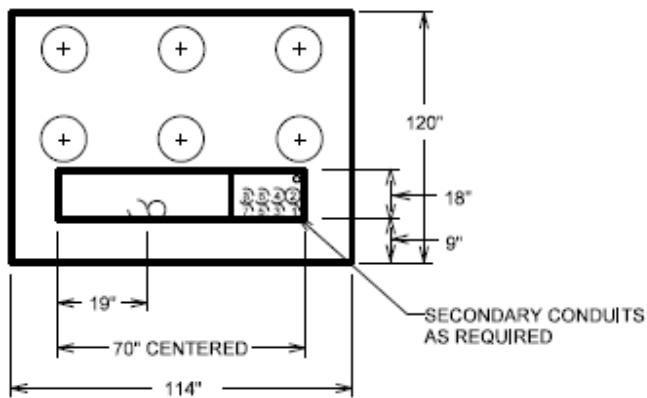
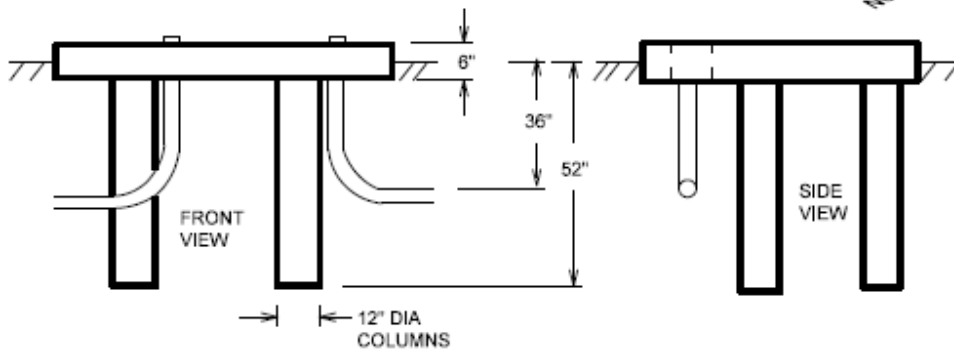
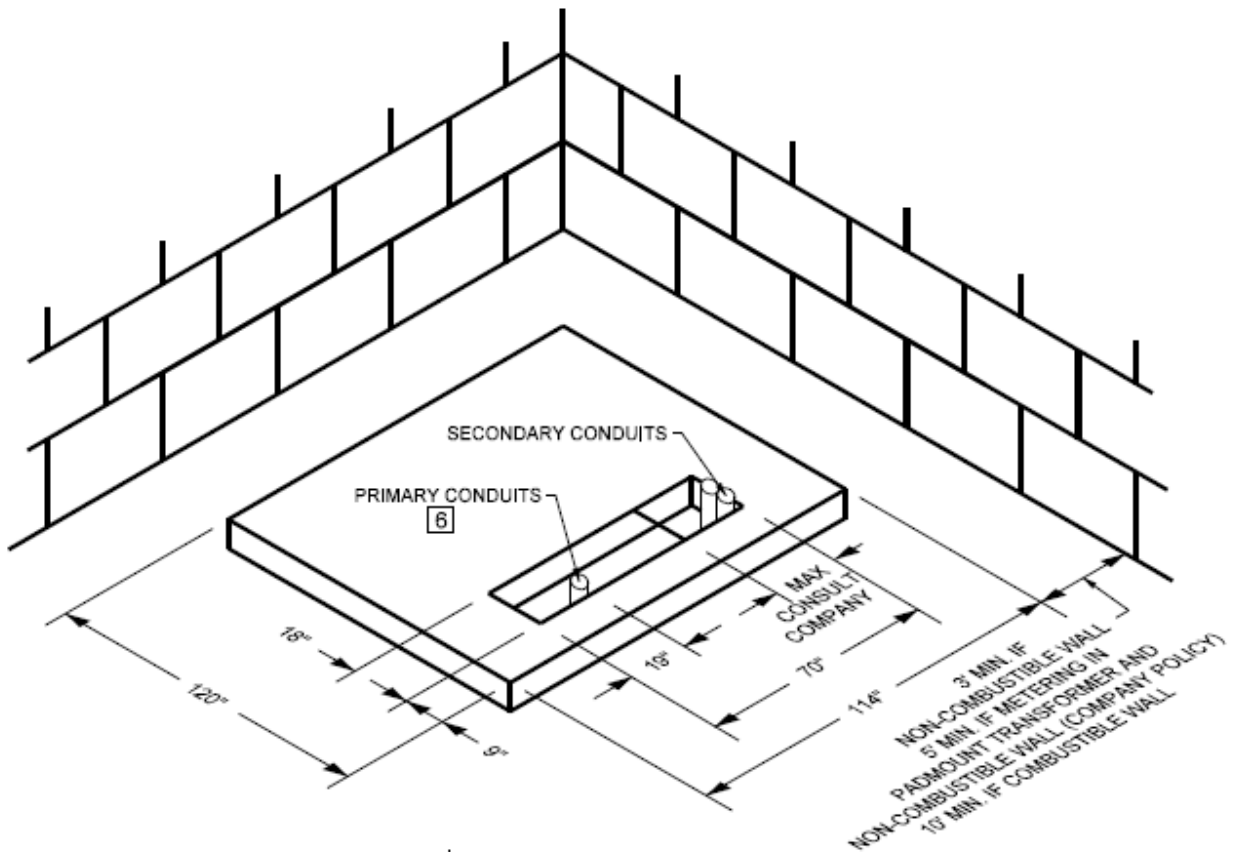

5-13 Primary Metering

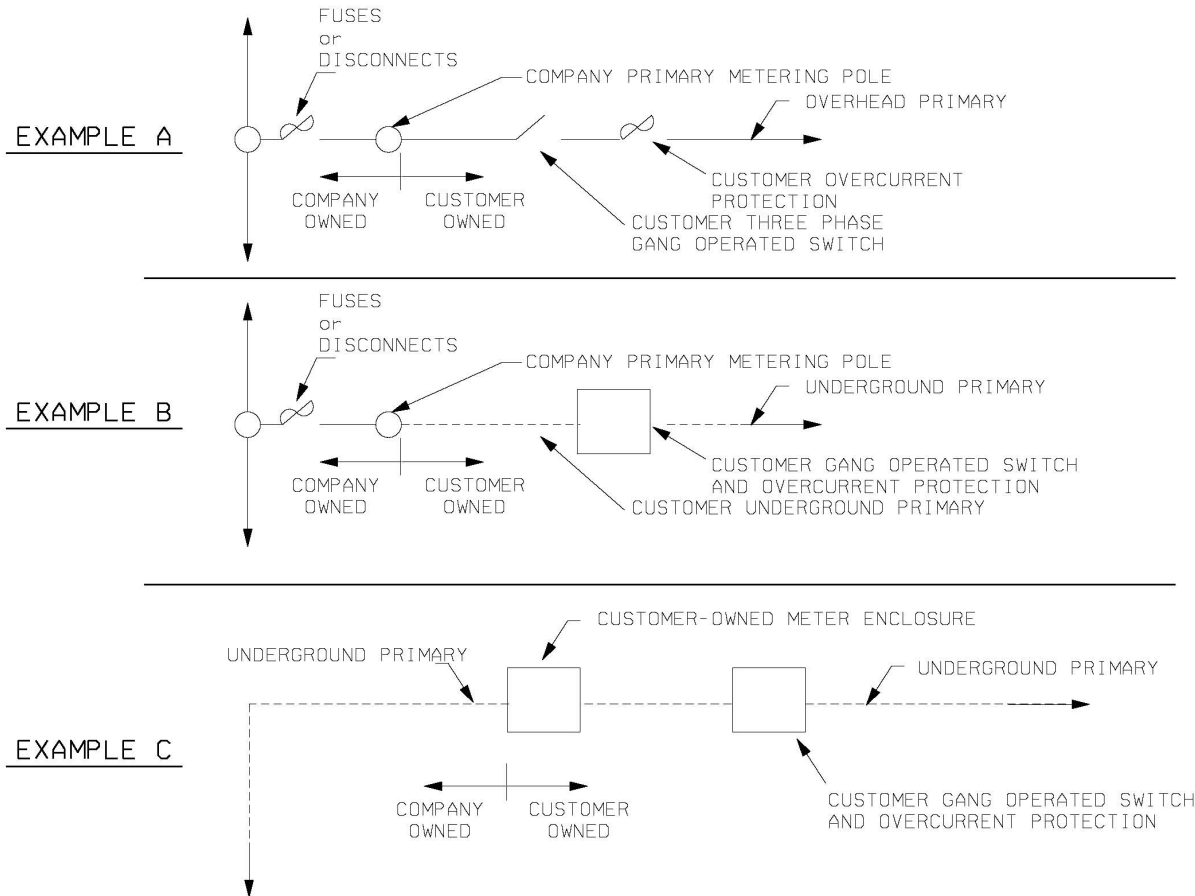

Notes:

1. Consult the Company for any 2.4/4.16 kV wye or higher primary voltages (7.2/12.47 kV wye is standard for UPPCO).
2. A gang-operated three-phase disconnect that the customer can operate must be installed.
3. Overcurrent protection must be installed in conjunction with the three-phase gang-operated disconnect. Consult the Company on coordination issues between the customer overcurrent protection and utility protection.
4. The customer-owned facilities must comply with the state electric code &/or the NEC. If the Company is selling an existing system, changes may be necessary. This is because Company lines are built to comply with the NESC.
5. Some of the key NEC requirements are in NEC 240.21, 450.3 & 695.5.
 - A. Overcurrent protection must be on the primary side of each transformer setting.
 - B. Overcurrent protection must be on the secondary side of each transformer setting ahead of the service, or what is now called the feeder by the NEC. This is not required if the customer determines that they have conditions of maintenance and supervision to ensure that only qualified people will monitor and service the transformer installation.
 - C. If primary feed to the transformer (feeder per NEC) is outside, then the requirements for secondary overcurrent protection at the transformer are not required. The NEC does require a single main in the secondary switchgear. The six disconnect rule does not apply.
 - D. The fire protection system has special overcurrent protection requirements.
6. Customer-owned, three-legged core transformers shall be avoided. Only grounded wye / grounded wye four or five legged core transformers shall be used. Loss of phase and ferroresonance is a concern.